

# ME MMAG

Rearmation motor

K16-C 07/2013

### PRODUCT PRESENTATION

The rearmation motor ME MMAG enables you to rearm the fire damper remotely. When powered, the rearmation motor will rotate the main axis until the damper blade is locked in its open position.

### LIST OF PARTS

Description	Characteristics	Quantity
Rearmation motor	ME MMAG	1
Installation bolt	DIN912 M4 x 80	3
Hex key	3mm	1
Label "KIT" (yellow)	ETIK-D042	1

### DETAILED CHARACTERISTICS

	ME MMAG
Tension	24/48 VDC
Consumption	24VDC: Pmax=10W   48VDC:Pmax=15W
Duration test	300 cycles
Ambient temperature	-30°C up to 50°C
Maintenance	Maintenance free

### ELECTRICAL WIRING DIAGRAM

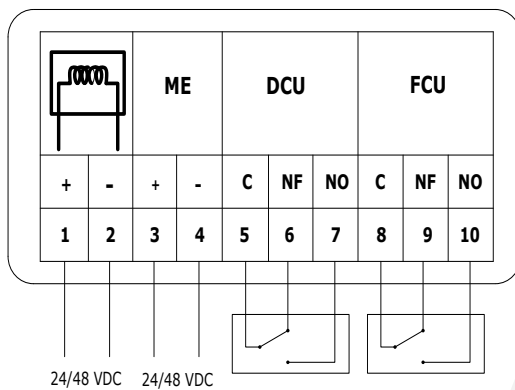

ME: Rearmation motor

DCU: Unipolar beginning of range switch

FCU: Unipolar end of range switch

### APPLICATIONS



fig. CU-LT



fig. CU-LT-1S



fig. CR60



fig. CR120



### OPERATION

#### MMAG

##### Manual rearmation (standard MMAG):

Turn the rearmation handle (1) clockwise or use a hex key 10

##### Motorized rearmation (kit ME MMAG):

- 1 Switch off the power supply for at least 10 sec.
- 2 Power the actuator for at least 30 sec. (respect the prescribed voltage and polarity).
- 3 The rearmation stops automatically if a torque > 15 Nm is detected

! Switch off the power supply after rearmation.  
! Switch off the power supply for at least 15sec. in between each rearmation cycle.

##### Manual unlocking (standard MMAG):

Use the unlocking button (2)

##### Remote controlled unlocking (kit VM/VD MMAG FDCU):

By sending an electrical impulse (VD) or by interrupting the power supply (VM) to the magnet's entrance of the FDCU printing plate

##### Automatic unlocking (standard MMAG):

When the fusible link melts at 72° C:

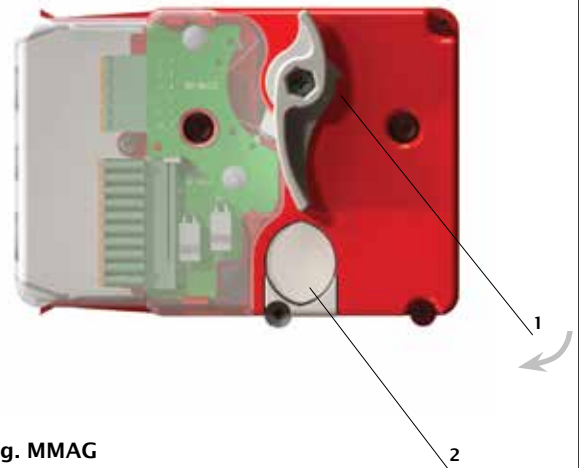
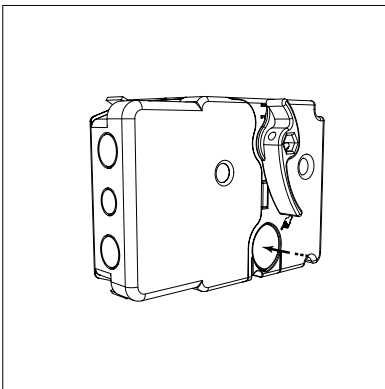

Fig. MMAG

### MOUNTING AND DISMANTLING

#### Dismantling of the motor



1. Unlock the existing mechanism.

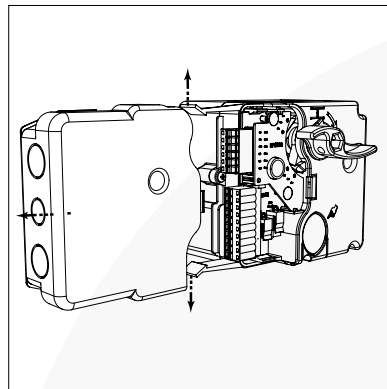

2. Loosen the cover by clicking it, then remove it.

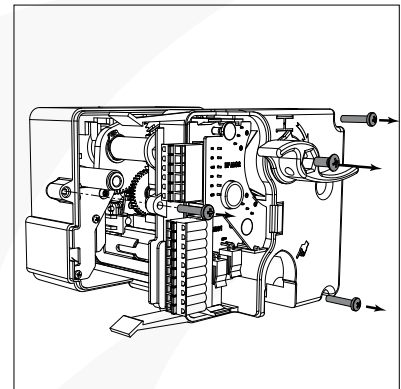

3. Unscrew the 4 installation screws of the cover and remove the cover.

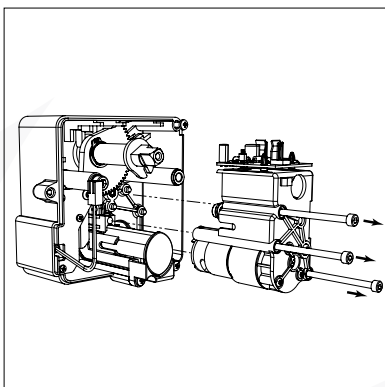

4. Unscrew the 3 installation screws and remove the existing motor.



### Mounting of the motor

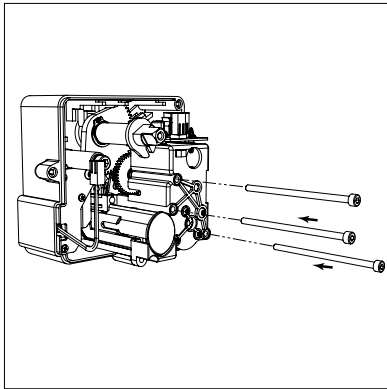

5. Screw the motor module in the space provided.

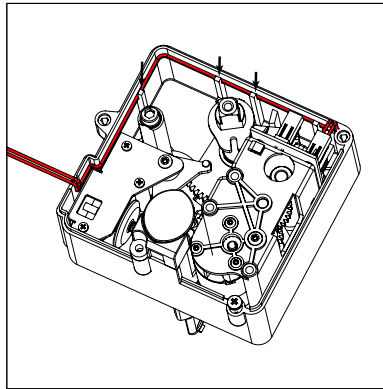

6. Mount the wire in the provided cable holders.

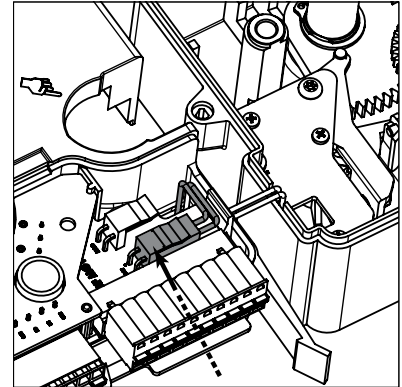

7. Plug the connector in the FDCU-circuit board on the indication 'MOT'.

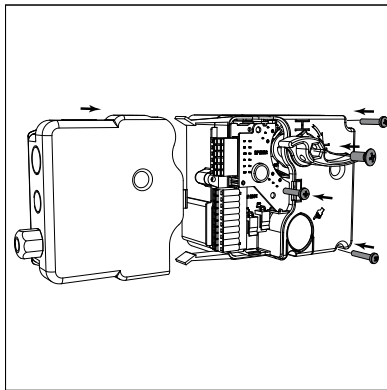

8. Mount the cap and tighten up with the 4 screws.

9. Mount the cable glands in the cover and mount the cover on the cap by clicking it.

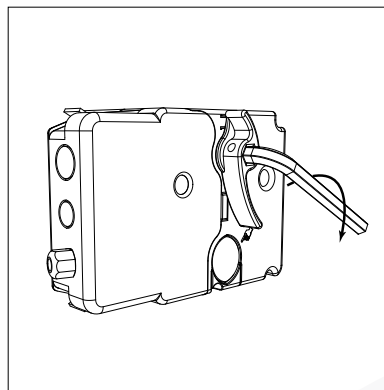

10. Test the good functioning of the mechanism.

11. Attach the label 'KIT' and fill in the necessary information.